

# MWPS-72085

## 30' Tilt-up Concrete Utility Building

### **CAUTION!**

Additional professional services will be required to tailor this plan to your situation, including but not limited to: assurance of compliance with codes and regulations; review of specifications for materials and equipment; supervision of site selection, bid letting and construction; and provision for utilities, waste management, roads or other access. **Furthermore, any deviation from the given specifications may result in structural failure, property damage, and personal injury including loss of life.**

### **WARRANTY DISCLAIMER**

This plan provides conceptual information only. **Neither midwest plan service nor any of the cooperating land-grant universities, or their respective agents or employees, have made, and do not hereby make, any representation, warranty or covenant with respect to the specifications in this plan.** Additional professional services will be required to tailor this plan to your situation, including but not limited to: assurance of compliance with codes and regulations; review of specifications for materials and equipment; supervision of site selection, bid letting and construction; and provision for utilities, waste management, roads or other access.

<b>MIDWEST PLAN SERVICE</b>
Cooperative Extension Work in Agriculture and Home Economics and Agricultural Experiment Stations of North Central Region - USDA Cooperating
30' Tilt-up Concrete Utility Building
Title Page
MIDWEST PLAN NO. 72085

PROVIDE LOUVER IN EACH GABLE END.  
SEE LOUVER DETAIL.

SPACE ROOF GRTS AND APPLY ROOFING  
8 SIDDING TO MFRS SPECS.

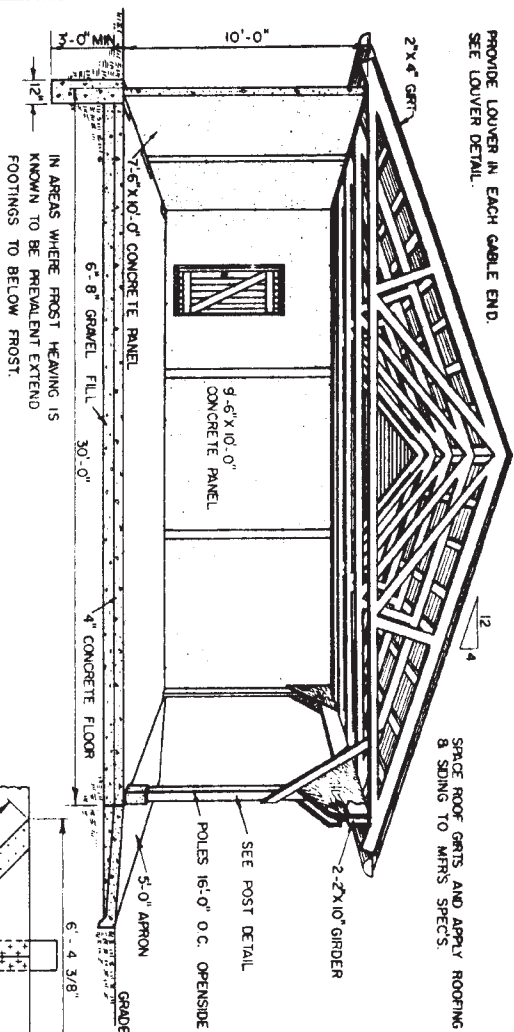

**INTERIOR**

**ALTERNATE CONNECTION**  
THIS JOINT IS MORE CONVENTIONAL BUT LESS EFFECTIVE THAN THE PLYWOOD DETAIL SHOWN.

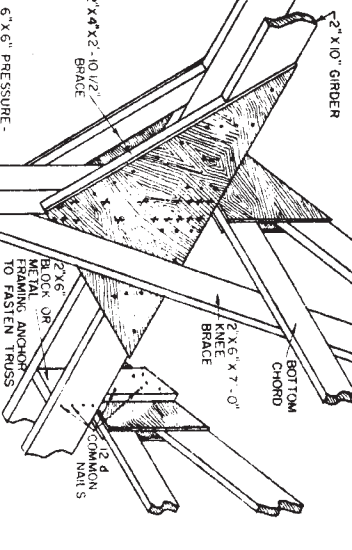
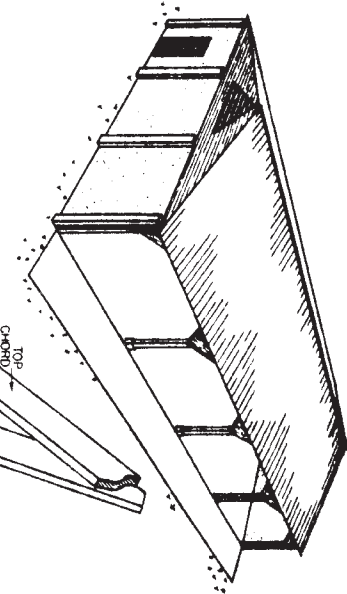
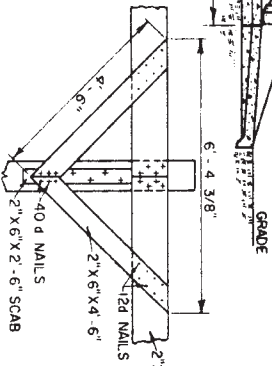

\* 8 d NAILS + 40 d NAILS UNLESS OTHERWISE NOTED

ALL NAILS DEFORMED, HANGING STEEL

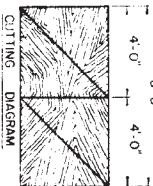

**POST DETAIL**

2 - 1/2" x 6" BOLT  
1/4" x 1" x 4'-0" STRAP U-SHAPED SET IN CONCRETE

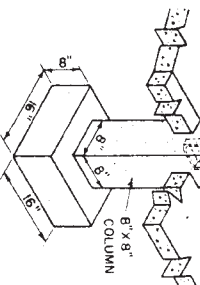

NOTE CAST AND ERECT PANELS FOR BACKWALL, THEN CAST PANELS FOR END WALLS  
NOTE CORNER PANELS ARE 3" NARROWER THAN THE OTHERS

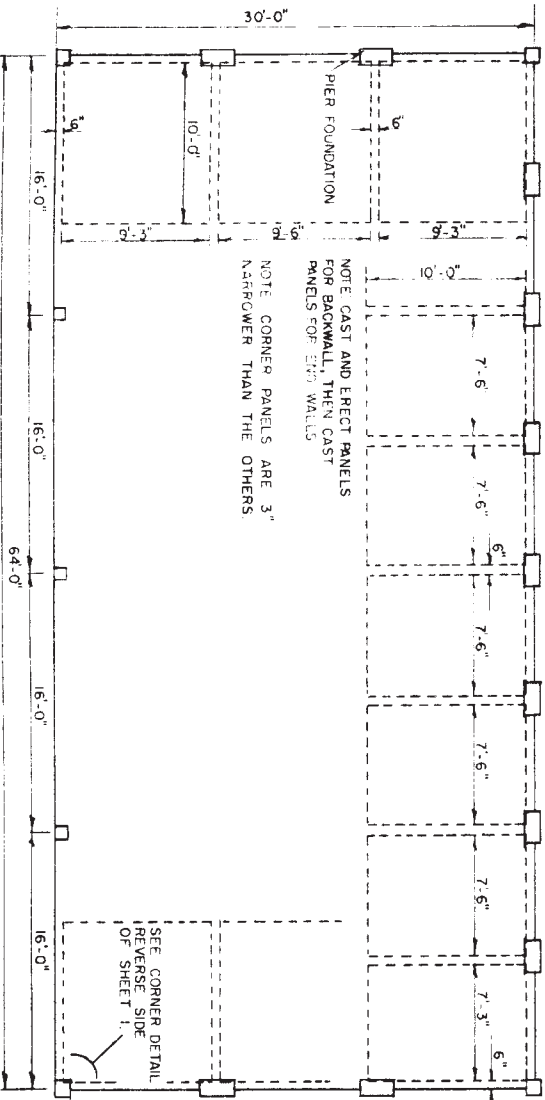

**PLAN**

SCALE 1/8" = 1'-0"

**MIDWEST PLAN SERVICE**

COOPERATIVE EXTENSION WORK IN AGRICULTURE AND HOME ECONOMICS  
AND AGRICULTURAL EXPERIMENT STATIONS  
OF NORTH CENTRAL REGION USDA COOPERATING

**30' TILT-UP CONCRETE UTILITY BUILDING**

6011 SHEET 1 OF 3 SHEETS  
MIDWEST PLAN NO. 72085

IF BARS ARE SPLICED AT TOP OF PIER ADD 18" LAP

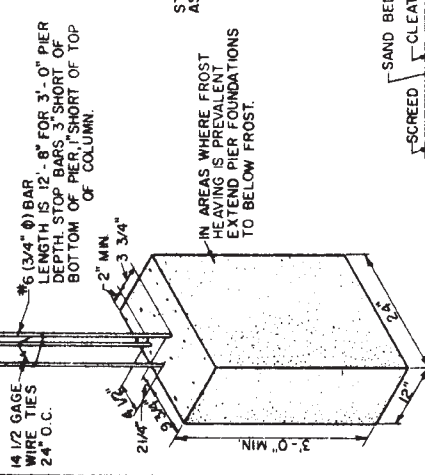

**PIER FOUNDATION**

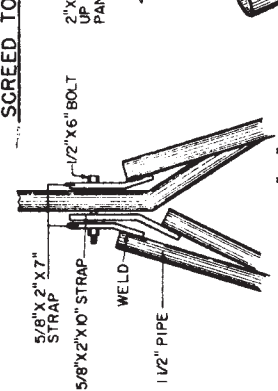

**DETAIL "C"**

**SCREEN TO PREPARE SAND BED**

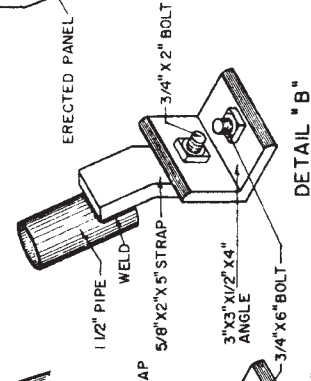
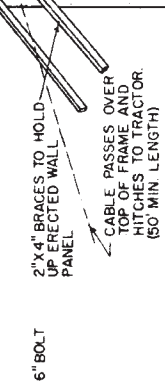

**DETAIL "B"**

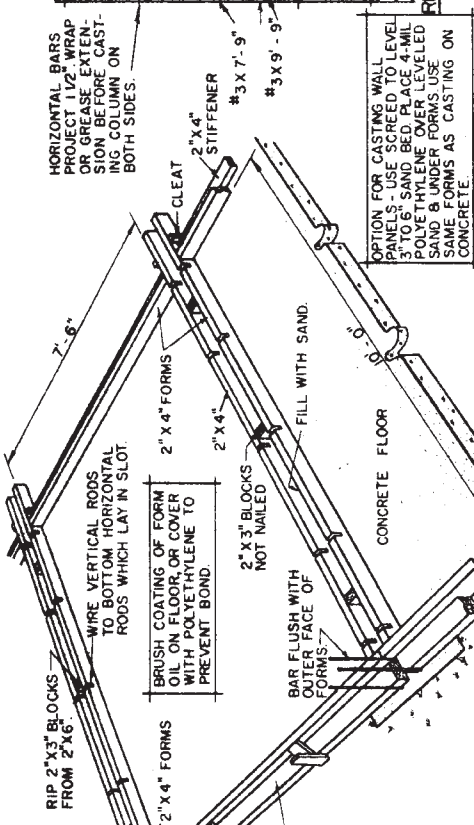

**FORMS FOR CASTING WALL PANELS**

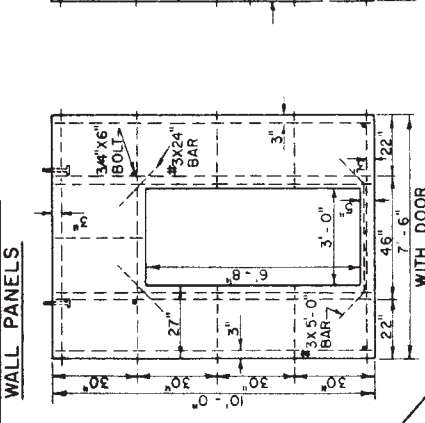

**REINFORCEMENT FOR WALL PANELS**

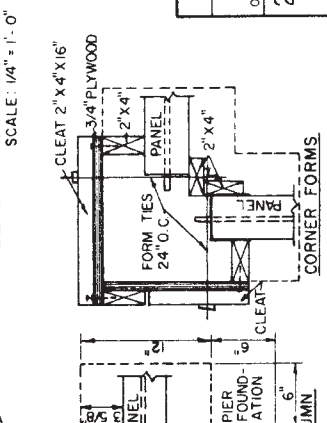

**REINFORCEMENT FOR WALL PANELS**



**REINFORCEMENT FOR WALL PANELS**

**DETAIL "A"**

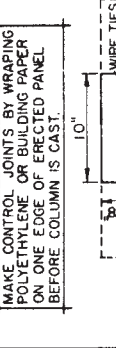

**DETAIL "A"**

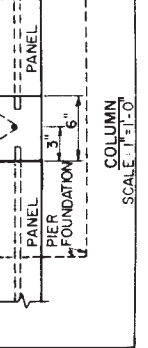

**TILTING FRAME**

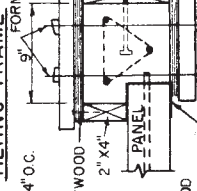

**TILTING FRAME**

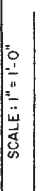

**COLUMN B FORM DETAILS**

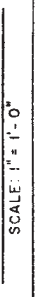

**COLUMN B FORM DETAILS**

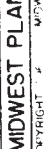

MIDWEST PLAN SERVICE  
COOPERATIVE EXTENSION WORK IN  
AGRICULTURE AND HOME ECONOMICS  
AND AGRICULTURAL EXPERIMENT STATIONS  
OF NORTH CENTRAL REGION USDA COOPERATING

24' TILT-UP CONCRETE  
UTILITY BUILDING

6011 SHEET 2 OF 3 SHEETS  
MIDWEST PLAN NO. 72084

COPYRIGHT © 1944 W. W. WEST, JR.